

2/2-way Solenoid Valve with servo diaphragm, G 3/8 - G 2



Type 6281 can be combined with...



Type 2508
Cable plug



Type 1078
Timer Unit



Type 2511
ASI Cable Plug

- User friendly - one solenoid for all orifices
- Waterhammer free and low noise
- Circuit function NC or NO
- Manual override optional
- Short installation length
- Explosion proof types

Servo-assisted solenoid valve with servo-diaphragm for the control of liquid or gaseous Medium. A pressure difference of 0.5 bar is required for a complete switchover. The modular coil system allows the interchange of the coils over all orifices to be in line with the nominal power and circuit function.

Power consumption		
Inrush AC [VA]	Hold (with hot coil)	
	AC [VA/W]	DC [W]
Circuit function A		
24	14/8	8 (9.5)
Circuit function B		
24	16/7	8 (9.5)
Ex-coil¹⁾ (Circuit function A)		
9	9	9

¹⁾ with internal rectifier

Circuit function A

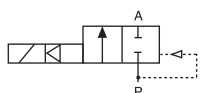

2/2-way valve NC, normally closed

Circuit function B

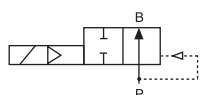

2/2-way valve NO, normally open

Technical data	
Orifice	DN 13 - 40 mm
Body material	Brass acc. to DIN EN 50930-6 (Stainless steel dezincification resistant on request)
Inner part of valve	Stainless steel, Brass, Plastic (PPS)
Seal material	NBR, EPDM, FKM
Media	NBR EPDM FKM
	Neutral fluids, e.g. compressed air, water Oil and fat-free fluids, hot water, acetone, aqueous alkali solution Hot air, per-solution
Ambient temperature	max. +55 °C
Media temperature	NBR EPDM FKM
	-10° to +80°C -30° to +90°C (with epoxy coil to +100°C) 0° to +90°C (with epoxy coil to +120°C)
Voltages	024/DC, 024/50-60, 230/50-60
Voltage tolerance	±10 %
Duty cycle	100% continuous rating
Electrical connection	Tag connector acc. to DIN EN 175301-803 Form A (previously DIN 43650) for cable plug Type 2508 (see Ordering chart for accessory, p. 5)
Protection class	IP 65 with cable plug
Installation	As required, preferably with actuator upright
Response times²⁾	0,1 - 4 seconds (depending on orifice and differential pressure)

²⁾ Measured at valve outlet at 6 bar and +20°C. *Opening*: pressure build-up 0 to 90%, *Schließen*: pressure decay 100 to 10%

Materials

Coil:	Polyamide ¹⁾ or epoxy ²⁾
Stopper: DN 10-40 mm:	1.4113
Short circuit ring: with Brass body: with Stainless steel body:	Copper (Cu) Silver (Ag)
Magnetic core: DN 10-40 mm:	1.4113
O-rings:	NBR, FKM, EPDM
Armature seal:	NBR, FKM, EPDM
Spring:	1.4310
O-rings:	NBR, FKM, EPDM
Diaphragm:	NBR, FKM, EPDM
Diaphragm-holder:	PPSGF40
Valve body:	Brass or Stainless steel 1.4408 (316)

¹⁾ with NBR, EPDM seal
²⁾ with FKM seal

Ordering chart for valves (other versions on request)

Circuit function A (NC, normally closed), Brass body

Circuit function	Port connection	Orifice [mm]	Kv value water [m ³ /h]	Pressure range [bar]	Weight [kg]	Item no. per voltage/frequency [V/Hz]			
						024/DC	024/50-60	230/50-60	
A 2/2-way valve NC 	Seal material NBR, Polyamide coil, Medium temperature -10...+80°C								
	G 3/8	13	3.8	0.2-16	0.58	221 841	221 842	221 843	
	G 1/2	13	3.8	0.2-16	0.54	221 844	221 845	221 846	
	G 3/4	13	3.8	0.2-16	0.59	221 847	221 848	221 849	
	G 3/4	20	8.5	0.2-16	0.89	221 850	221 851	221 852	
	G 1	20	8.5	0.2-16	1.0	221 853	221 854	221 855	
	G 1	25	12	0.2-16	1.3	221 856	221 857	221 858	
	G 1 1/4	25	12	0.2-16	1.5	221 859	221 860	221 861	
	G 1 1/2	40	30	0.2-16	3.0	221 862	221 863	221 864	
	G 2	40	30	0.2-16	3.2	221 865	221 866	221 867	
	Seal material NBR, Polyamide coil, Medium temperature -10...+80°C, with manual override								
	G 1/2	13	3.8	0.2-16	0.54	221 952	-	221 953	
	G 3/4	13	3.8	0.2-16	0.59	221 954	-	221 955	
	G 3/4	20	8.5	0.2-16	0.89	221 956	-	221 957	
	G 1	20	8.5	0.2-16	1.0	221 958	-	221 959	
	G 1	25	12	0.2-16	1.3	221 960	-	221 961	
	G 1 1/4	25	12	0.2-16	1.5	221 962	-	221 963	
G 1 1/2	40	30	0.2-16	3.0	221 964	-	221 965		
G 2	40	30	0.2-16	3.2	221 966	-	221 967		

Please note that the cable plug has to be ordered separately, see Ordering chart for accessory and separate datasheet, Type 2508

Ordering chart for valves, continued

Circuit function A (NC, normally closed), Brass body

Circuit function	Port connection	Orifice [mm]	Kv value water [m ³ /h]	Pressure range [bar]	Weight [kg]	Item no. per voltage/frequency [V/Hz]			
						024/DC	024/50-60	230/50-60	
A 2/2-way valve NC 	Seal material FKM, Epoxy coil, Medium temperature 0...+120°C								
	G 3/8	13	3.8	0.2-16	0.58	221 868	221 869	221 870	
	G 1/2	13	3.8	0.2-16	0.54	221 871	221 872	221 873	
	G 3/4	13	3.8	0.2-16	0.59	221 874	221 875	221 876	
	G 3/4	20	8.5	0.2-16	0.89	221 877	221 878	221 879	
	G 1	20	8.5	0.2-16	1.0	221 880	221 881	221 882	
	G 1	25	12	0.2-16	1.3	221 883	221 884	221 885	
	G 1 1/4	25	12	0.2-16	1.5	221 886	221 887	221 888	
	G 1 1/2	40	30	0.2-16	3.0	221 889	221 890	221 891	
	G 2	40	30	0.2-16	3.2	221 892	221 893	221 894	
	Seal material EPDM, Polyamide coil, Medium temperature -30...+90°C								
	G 3/8	13	3.8	0.2-16	0.58	221 895	221 896	221 897	
	G 1/2	13	3.8	0.2-16	0.54	221 898	221 899	221 900	
	G 3/4	13	3.8	0.2-16	0.59	221 901	221 902	221 903	
	G 3/4	20	8.5	0.2-16	0.89	221 904	221 905	221 906	
	G 1	20	8.5	0.2-16	1.0	221 907	221 908	221 909	
	G 1	25	12	0.2-16	1.3	221 910	221 911	221 912	
	G 1 1/4	25	12	0.2-16	1.5	221 913	221 914	221 915	
	G 1 1/2	40	30	0.2-16	3.0	221 916	221 917	221 918	
	G 2	40	30	0.2-16	3.2	221 919	221 920	221 921	

Circuit function B (NO, normally open), Brass body

Circuit function	Port connection	Orifice [mm]	Kv value water [m ³ /h]	Pressure range [bar]	Weight [kg]	Item no. per voltage/frequency [V/Hz]			
						024/DC	024/50	230/50	
B 2/2-way valve NO 	Seal material NBR, Epoxy coil, Medium temperature -10...+80°C								
	G 3/8	13	3.8	0.2-16	0.58	221 923	221 924	221 925	
	G 1/2	13	3.8	0.2-16	0.54	221 926	221 928	221 929	
	G 3/4	13	3.8	0.2-16	0.59	221 930	221 931	221 933	
	G 3/4	20	8.5	0.2-16	0.89	221 934	221 935	221 936	
	G 1	20	8.5	0.2-16	1.0	221 937	221 938	221 939	
	G 1	25	12	0.2-16	1.3	221 940	221 941	221 942	
	G 1 1/4	25	12	0.2-16	1.5	221 943	221 944	221 945	
	G 1 1/2	40	30	0.2-16	3.0	221 946	221 947	221 948	
	G 2	40	30	0.2-16	3.2	221 949	221 950	221 951	

Please note that the cable plug has to be ordered separately, see Ordering chart for accessory and separate datasheet, Type 2508

Ordering chart for valves, continued

Circuit function A (NC, normally closed), Stainless steel body

Circuit function	Port connection	Orifice [mm]	Kv value water [m³/h]	Pressure range [bar]	Weight [kg]	Item no. per voltage/frequency [V/Hz]			
						024/DC	024/50-60	230/50-60	
A 2/2-way valve NC 	Seal material NBR, Polyamide coil, Medium temperature -10...+80°C								
	G 1/2	13	3.8	0.2-16	0.54	221 968	221 969	221 970	
	G 3/4	20	8.5	0.2-16	0.86	221 971	221 972	221 973	
	G 1	20	8.5	0.2-16	0.97	221 974	221 975	221 976	
	G 1	25	12	0.2-16	1.3	221 977	221 978	221 979	
	G 1 1/4	25	12	0.2-16	1.4	221 980	221 981	221 982	
	G 1 1/2	40	30	0.2-16	2.8	221 983	221 984	221 985	
	G 2	40	30	0.2-16	3.0	221 986	221 987	221 988	
	Seal material FKM, Epoxy coil, Medium temperature 0...+120°C								
	G 1/2	13	3.8	0.2-16	0.54	221 989	221 990	221 991	
	G 3/4	20	8.5	0.2-16	0.86	221 992	221 993	221 994	
	G 1	20	8.5	0.2-16	0.97	221 995	221 996	221 997	
	G 1	25	12	0.2-16	1.3	221 998	221 999	222 000	
	G 1 1/4	25	12	0.2-16	1.4	222 001	222 002	222 003	
	G 1 1/2	40	30	0.2-16	2.8	222 004	222 005	222 006	
	G 2	40	30	0.2-16	3.0	222 007	222 008	222 009	
	Seal material EPDM, Polyamide coil, Medium temperature -30...+90°C								
	G 1/2	13	3.8	0.2-16	0.54	222 010	222 011	222 012	
	G 3/4	20	8.5	0.2-16	0.86	222 013	222 014	222 015	
	G 1	20	8.5	0.2-16	0.97	222 016	222 017	222 018	
	G 1	25	12	0.2-16	1.3	222 019	222 020	222 021	
	G 1 1/4	25	12	0.2-16	1.4	222 022	222 023	222 024	
	G 1 1/2	40	30	0.2-16	2.8	222 025	222 026	222 027	
	G 2	40	30	0.2-16	3.0	222 028	222 029	222 031	

Circuit function B (NO, normally open), Stainless steel body

Circuit function	Port connection	Orifice [mm]	Kv value water [m³/h]	Pressure range [bar]	Weight [kg]	Item no. per voltage/frequency [V/Hz]			
						024/DC	024/50	230/50	
B 2/2-way valve NO 	Seal material FKM, Epoxy coil, Medium temperature 0...+120°C								
	G 1/2	13	3.8	0.2-16	0.54	228 387	228 388	228 389	
	G 3/4	20	8.5	0.2-16	0.86	228 390	228 391	228 392	
	G 1	25	12	0.2-16	1.3	228 393	228 394	228 395	
	G 1 1/4	25	12	0.2-16	1.4	228 396	228 397	228 398	
	G 1 1/2	40	30	0.2-16	2.8	228 399	228 400	228 401	
	G 2	40	30	0.2-16	3.0	228 402	228 403	228 404	

Please note that the cable plug has to be ordered separately, see Ordering chart for accessory and separate datasheet, Type 2508

Ordering chart for valves, continued

Circuit function A, (NC, normally closed)¹⁾ explosion proofed version ATEX (Type of protection EX M II G/D T4)

Circuit function	Port connection	Orifice [mm]	Kv value water [m³/h]	Pressure range [bar]	Weight [kg]	Item no. per voltage/frequency [V/Hz]	
						024/UC	230/UC
A 2/2-way valve NC 	Seal material NBR, Brass body, Medium temperature -10...+80°C						
	G 1/2	13	3.8	0.2-16	0.84	228 405	228 406
	G 3/4	20	8.5	0.2-16	1.2	228 407	228 408
	G 1	25	12	0.2-16	1.7	228 409	228 410
	G 1 1/4	25	12	0.2-16	1.8	228 411	228 412
	G 1 1/2	40	30	0.2-16	3.3	228 413	228 414
	G 2	40	30	0.2-16	3.5	228 415	228 416
	Seal material FKM, Stainless steel body, Medium temperature 0...+90°C						
	G 1/2	13	3.8	0.2-16	0.84	228 417	228 418
	G 3/4	20	8.5	0.2-16	1.2	228 419	228 420
	G 1	25	12	0.2-16	1.6	228 421	228 422
	G 1 1/4	25	12	0.2-16	1.7	228 423	228 424
	G 1 1/2	40	30	0.2-16	3.1	228 425	228 426
	G 2	40	30	0.2-16	3.3	228 427	228 428

¹⁾ only with Epoxy coil available

Please note: Electrical connection for explosion proof version with 3m cable. Version with terminal box on request.

i Further versions on request

- Port connection**
NPT, Rc
- Voltage**
Further voltages
- Temperature**
EPDM version up to +100°C with epoxy coil
FKM version up to +120°C with epoxy coil
- Material**
Brass dezincification resistant
- Approvals**
European gas approval
EPDM with KTW W270

Ordering chart for accessory

Cable plug Type 2508 according to DIN EN 175301-803 Form A

	Circuitry	Voltage / frequency	Item no.
	None (standard)	0 - 250 V AC/DC	008 376
	further versions see datasheet Type 2508		

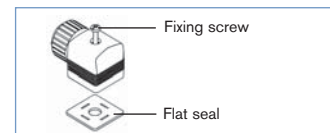

The delivery of a cable plug includes the flat seal and the fixing screw. For other cable plug versions acc. to DIN EN 175301-803 Form A (previously DIN 43650), see separate datasheet Type 2508.

Dimensions [mm]

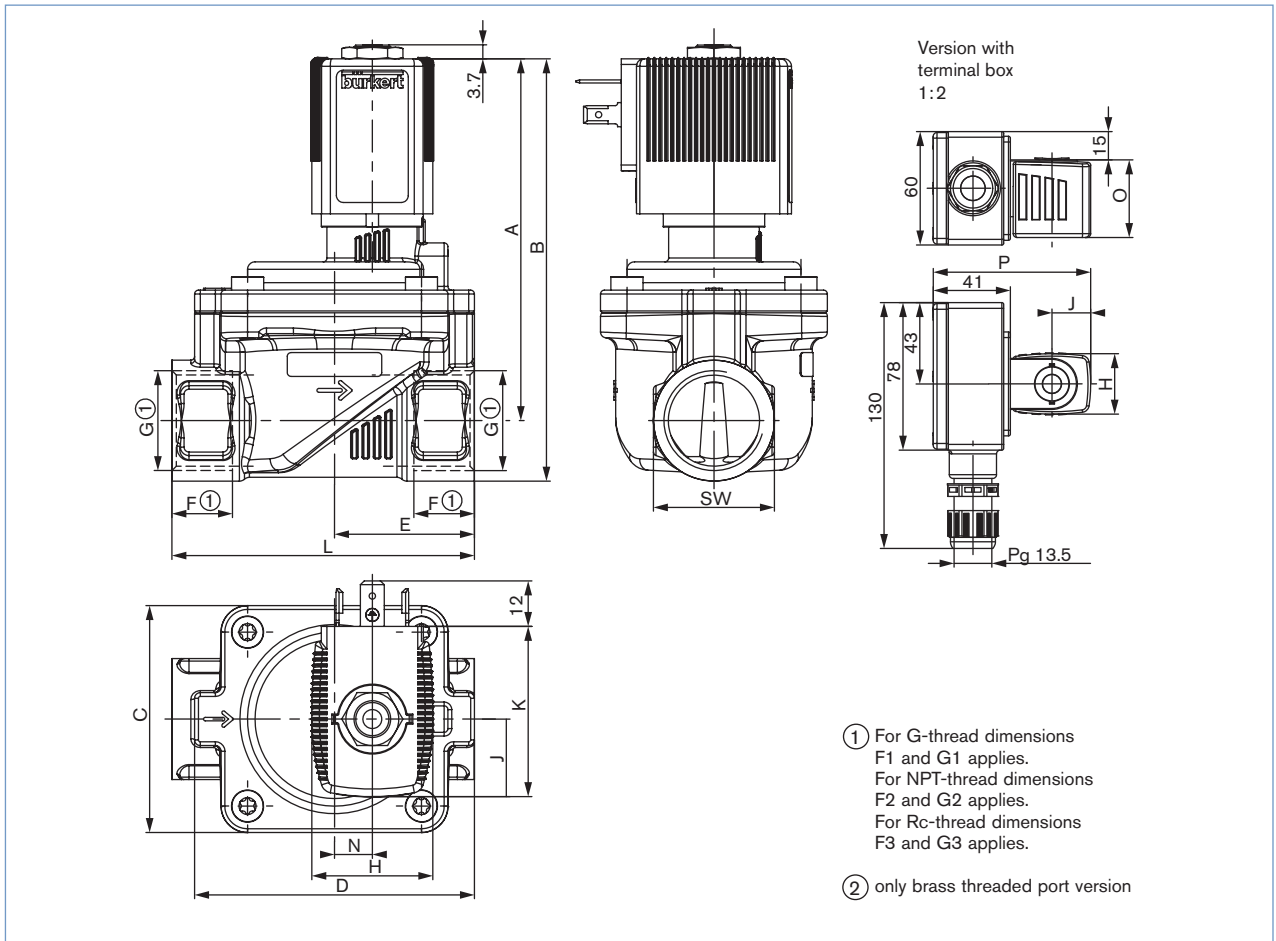

① For G-thread dimensions
 F1 and G1 applies.
 For NPT-thread dimensions
 F2 and G2 applies.
 For Rc-thread dimensions
 F3 and G3 applies.

② only brass threaded port version

DN	A	B	C	D	E	* G		* NPT		* Rc		H	J	K	L	SW	N	O	P	Coil size
						F1①	G1①	F2①	G2①	F3①	G3①									
② 13	87.2	100.7	42	54.5	27.25	12	G 3/8	-	-	-	-	32	20.5	45	58	27	-	41	83.3	5
13	87.2	100.7	42	54.5	32.5	14	G 1/2	13.7	NPT 1/2	13.2	Rc 1/2	32	20.5	45	65	27	-	41	83.3	5
13	89.2	105.2	42	54.5	32.5	16	G 3/4	14	NPT 3/4	-	-	32	20.5	45	65	32	-	41	83.3	5
20	95.7	111.7	60	74	37	16	G 3/4	14	NPT 3/4	14.5	Rc 3/4	32	20.5	45	80	32	10	41	83.3	5
	98.2	118.7			37.5	18	G1	16.8	NPT 1	-	-				80	41				
25	102.7	123.2	70	85	46	18	G1	16.8	NPT 1	16.8	Rc 1	32	20.5	45	95	41	15	41	83.3	5
	107.7	132.7			46	20	G1 1/4	17.3	NPT 1 1/4	19.1	Rc 1 1/4				95	50				
40	121.7	151.7	99	114	61	22	G1 1/2	17.3	NPT 1 1/2	19.1	Rc 1 1/2	32	20.5	45	126	60	23	41	83.3	5
	127.7	162.7			64	24	G2	17.6	NPT 2	23.4	Rc 2				132	70				
② 13	87.2	100.7	42	54.5	27.25	12	G 3/8	-	-	-	-	40	23.5	51	58	27	-	41.4	89.3	6
13	87.2	100.7	42	54.5	32.5	14	G 1/2	13.7	NPT 1/2	13.2	Rc 1/2	40	23.5	51	65	27	-	41.4	89.3	6
13	89.2	105.2	42	54.5	32.5	16	G 3/4	14	NPT 3/4	-	-	40	23.5	51	65	32	-	41.4	89.3	6
20	95.7	111.7	60	74	37	16	G 3/4	14	NPT 3/4	14.5	Rc 3/4	40	23.5	51	80	32	10	41.4	89.3	6
	98.2	118.7			37.5	18	G1	16.8	NPT 1	-	-				80	41				
25	102.7	123.2	70	85	46	18	G1	16.8	NPT 1	16.8	Rc 1	40	23.5	51	95	41	15	41.4	89.3	6
	107.7	132.7			46	20	G1 1/4	17.3	NPT 1 1/4	19.1	Rc 1 1/4				95	50				
40	121.7	151.7	99	114	61	22	G1 1/2	17.3	NPT 1 1/2	19.1	Rc 1 1/2	40	23.5	51	126	60	23	41.4	89.3	6
	127.7	162.7			64	24	G2	17.6	NPT 2	23.4	Rc 2				132	70				

To find your nearest Bürkert facility, click on the orange box → www.buerkert.com

In case of special application conditions,
 please consult for advice.

Subject to alteration.
 © Christian Bürkert GmbH & Co. KG

1201/2_EU-en_00895124